

# Dewatering Pumps

## Installation, Operation and Maintenance Manual

### Owner's Information

Pump Model Number: \_\_\_\_\_  
 Pump Serial Number: \_\_\_\_\_  
 Motor Model Number: \_\_\_\_\_  
 Motor Serial Number: \_\_\_\_\_  
 Dealer: \_\_\_\_\_  
 \_\_\_\_\_  
 Dealer Telephone: \_\_\_\_\_  
 Purchase Date: \_\_\_\_\_  
 Installation Date: \_\_\_\_\_

### Table of Contents

<u>SUBJECT</u>	<u>PAGE</u>
Data Plate Interpretation .....	2
Product Description .....	3
Applications .....	3
Technical Data.....	3
Motor Data.....	3
Dimensions .....	3
Performance Curves .....	4
Installation .....	4
Electrical Connections .....	5
Level Regulators .....	5
Operation .....	6
Care and Maintenance .....	6
Inspection.....	6
Tightening and Lubricating Screws .....	6
Spare Parts .....	7
Limited Warranty .....	8

## Safety Instructions

**TO AVOID SERIOUS OR FATAL PERSONAL INJURY OR MAJOR PROPERTY DAMAGE, READ AND FOLLOW ALL SAFETY INSTRUCTIONS IN THE MANUAL AND ON THE PUMP.**



This is a **SAFETY ALERT SYMBOL**. When you see this symbol on the pump or in the manual, look for one of the following signal words and be alert to the potential for personal injury or property damage.

**⚠ DANGER** Warns of hazards that **WILL** cause serious personal injury, death or major property damage.

**⚠ WARNING** Warns of hazards that **CAN** cause serious personal injury, death or major property damage.

**⚠ CAUTION** Warns of hazards that **CAN** cause personal injury or property damage.

**NOTICE:** INDICATES SPECIAL INSTRUCTIONS WHICH ARE VERY IMPORTANT AND MUST BE FOLLOWED.

**THIS MANUAL IS INTENDED TO ASSIST IN THE INSTALLATION AND OPERATION OF THIS UNIT. THOROUGHLY REVIEW ALL INSTRUCTIONS AND WARNINGS PRIOR TO PERFORMING ANY WORK ON THIS PUMP.**

**MAINTAIN ALL SAFETY DECALS.**



- ⚠** Install, ground and wire according to local and National Electrical Code Requirements.
- ⚠** Install an all leg disconnect switch near the pump.
- ⚠** Disconnect and lockout electrical power before installing or servicing the pump.
- ⚠** Electrical supply must match motor's nameplate specifications. Incorrect voltage can cause fire, damage motor and void the warranty.

- ⚠** Single phase pump motors are equipped with an automatic thermal protector, which opens the motor's electrical circuit when an overload condition exists. This can cause the pump to start unexpectedly.

## Data Plate Interpretation

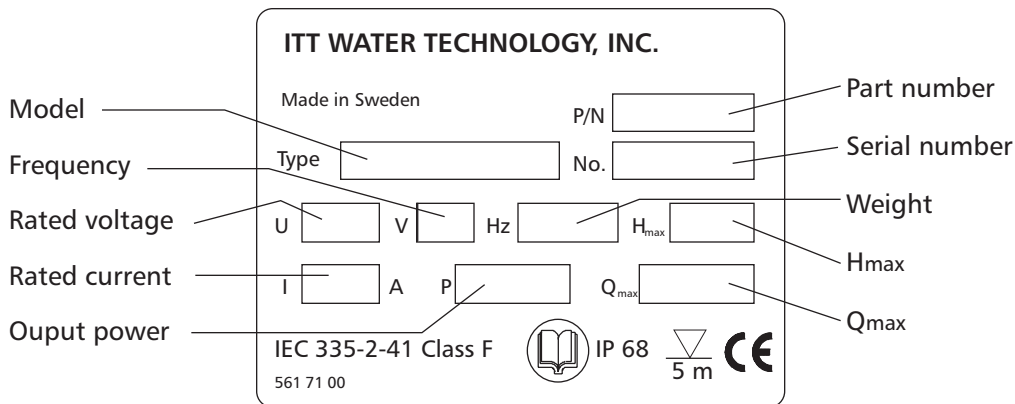

**Note:** The Nameplate HP ratings on these dewatering pumps have been converted from the common European Kw designation. This created a slight difference between the HP rating used in our literature versus the pump's nameplate HP. Therefore, when using this manual:

½ HP Model = a .6 nameplate rating

1 HP Model = a 1.1 nameplate rating

## Product Description

### APPLICATIONS

Dewatering pumps are intended to be used for pumping water which may contain abrasive particles. The pumped liquid may contain particles up to a size which corresponds to the openings in the strainer.

### TECHNICAL DATA

Liquid temperature: 41- 95°F (5-35°C)

The pH of the pumped liquid: 3-9

Depth of immersion: max. 16.5 ft (5 m).

#### Weight without motor cable:

½ HP	20 lb	(9.0 kg)
1 HP	25 lb	(11.5 kg)

#### Discharge connection:

2" (50 mm) hose, 2"-11.5 NPSM or 2" NPT

#### Oil type:

Mobil Whiterex or Shell Ondina etc. with viscosity class ISO VG 15 to 32. 0.17 liter.

**⚠ WARNING** The pump may not be used in an explosive or flammable environment or for pumping flammable liquids.

## MOTOR DATA

½ HP, 60 Hz., 1Ø  
440 W, 3200 RPM

Voltage V	Rated Current A	Starting Current A
115	5.5	16
230	2.9	6

1 HP, 60 Hz., 1Ø  
850 W, 3300 RPM

Voltage V	Rated Current A	Starting Current A
115	9.8	36
230	4.9	14

## DIMENSIONS

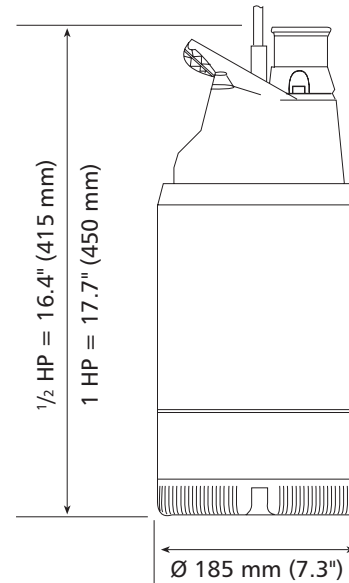

## Performance Curves

---

Each pump is tested in accordance with ISO 2548.

½ HP, 60 Hz, 1Ø

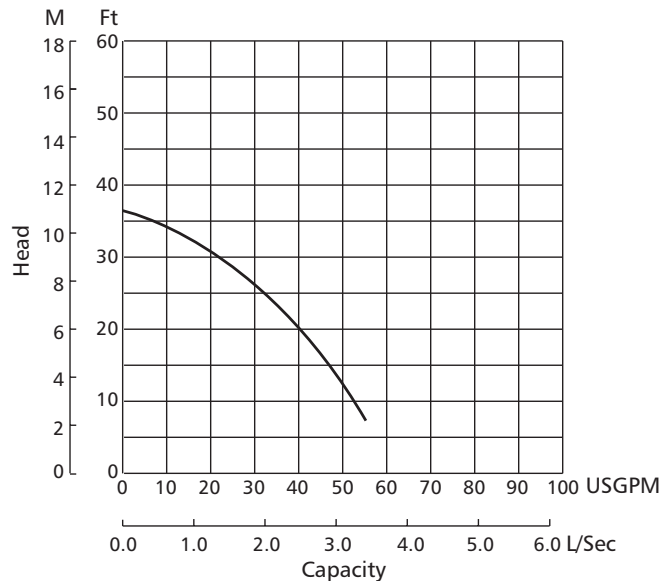

1 HP, 60 Hz, 1Ø

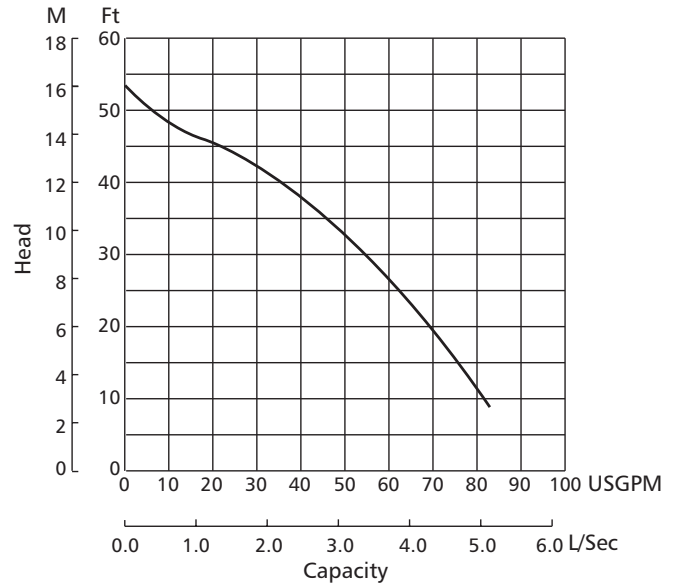

## Installation

---

Run the cables so that they do not have any sharp bends and are not pinched.

Connect the motor cable to a grounded power supply. See “Electrical connections”.

Connect a discharge hose to the threaded discharge connection.

Lower the pump into the sump.

Place the pump on a base which will prevent it from sinking into a soft sump bottom. Alternatively, the pump can be suspended by its handle just above the sump bottom.

**NOTICE: WHERE REQUIRED BY LOCAL AUTHORITIES AN ACCEPTABLE MOTOR-CIRCUIT SWITCH OR OTHER DISCONNECTING DEVICE SHALL BE PROVIDED AT THE TIME OF INSTALLATION.**

**NOTICE: AT CERTAIN INSTALLATIONS AND OPERATION POINTS ON THE PUMP CURVE THE NOISE LEVEL, 70 DB, CAN BE EXCEEDED.**

## Electrical Connections

**⚠ WARNING** All electrical equipment must be grounded. This applies to both pump equipment and any monitoring equipment. Failure to heed this warning may cause a lethal accident. Make sure that the ground lead is correctly connected by testing it.

All electrical work shall be carried out under the supervision of an authorized electrician.

Local codes and regulations shall be complied with.

Check that the main voltage and frequency agree with the specifications on the pump data plate.

Make sure that the pump is correctly grounded.

**⚠ WARNING** If people are likely to come into physical contact with the pump or pumped media (liquid), e.g. on construction sites or farms etc., the grounded socket must have an additional ground-fault protection device (GFI) connected. When pumping near a lake (Jetties, beaches, ponds and fountains etc.) a safety-distance of at least 65 ft. (20 meters) between the people and the pump is applicable. The pump must never be placed directly into a swimming pool unless it is shut down for maintenance. If used in connection with swimming pools, special safety regulations apply.

## LEVEL REGULATORS

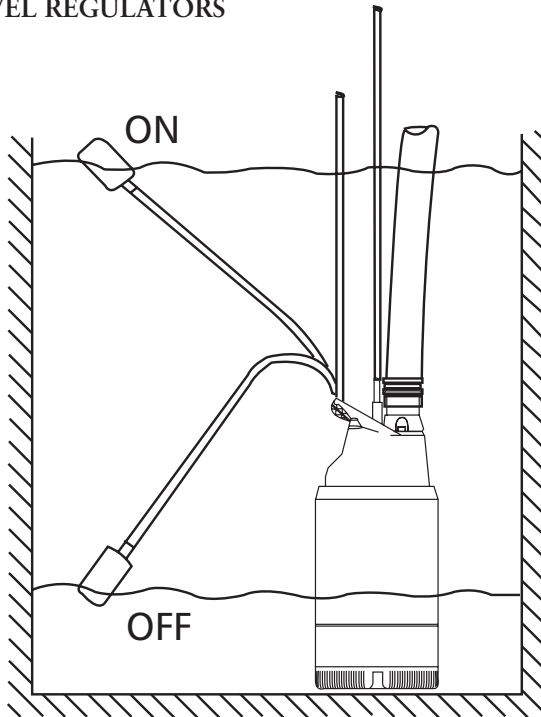

Pump control by use of level switch.

## Operation

---

### BEFORE STARTING

Check the oil level in the oil casing.

Remove the fuses or open the circuit breaker and check that the impeller can be rotated by hand.

Check that the monitoring equipment (if any) works.

Check the direction of rotation. The impeller shall rotate clockwise, as viewed from above. When started, the pump will jerk in the opposite direction to the direction in which the impeller rotates. See the figure.

### STARTING JERK

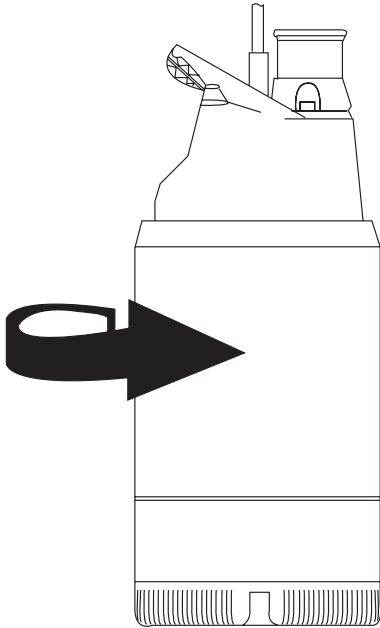

### CLEANING

If the pump has been running in very dirty water, let it run for a while in clean water, or flush it through the discharge connection. If clay, cement or other similar dirt is left in the pump it may clog the impeller and seal, preventing the pump from working.

During a long period out of operation, the pump must be test run every other month to prevent the mechanical seals from sticking together.

**WARNING** Watch out for the starting jerk, which can be powerful.

**WARNING** Always lift the pump by its carrying handle or lifting eyes, never by the motor cable or the hose.

## Care and Maintenance

---

### INSPECTION

Regular inspection and preventive maintenance ensure more reliable operation.

The pump should be inspected at least twice a year, more frequently under severe operating conditions.

### TIGHTENING SCREWS

During assembly or service of the pump we recommend that the screws be tightened to approximately 4.5 - 6 ft lbs (6-8Nm).

This tightening torque ensures that the parts are correctly fastened and that the pump will operate as intended.

**NOTICE:** Make sure that the oil-plug screw is not tightened too hard.

**WARNING** Be sure to disconnect the power supply before attempting inspection, as the pump may start automatically.

### LUBRICATING SCREWS

To maintain screw tightness use a little mineral oil on all non-stainless screws (not synthetic lubricants!).

**NOTICE:** When using stainless steel screws on stainless steel parts we recommend that ARAL DEGOL GS 460 or National Chemseal THREAD-EZE lubricants be used to prevent screws from seizing or getting stuck.

**WARNING** If the motor cable on this pump is damaged the cable may only be changed by a repair shop authorized by the manufacturer. This is necessary as special tools are required to change the cable.

## Spare Parts

### SPARE PART KITS

Spare parts for the dewatering pumps are available in handy kits to make service and repair work easier. Each kit contains an instruction sheet together with the replacement parts.

Kit type	½ HP 60Hz, Kit No.	1 HP 60Hz, Kit No.
Impeller Kit	15K11	15K12
Diffuser Kit	15K13	15K13
Outer Seal Kit	15K14	15K14
Fastener Kit	15K15	15K15

#### Each Kit contains the following parts:

Impeller Kit	Impeller, Impeller screw, Protective plug, Washer, Assembly instruction
Diffuser Kit	Diffuser, Barrel nuts, Screws, Washers, Assembly instruction
Outer seal Kit	Mechanical face-seal unit, Assembly instruction
Fastener Kit	Barrel nuts, Washers, Socket head screws

Please contact your local distributor for further details regarding spare parts etc.

## MAIN PARTS

Item	Denomination
1	Discharge connection
2	Cable entry
3	Handle / cover
4	Support bearing
5	Pump casing
6	Main bearing
7	Inner mechanical seal
8	Outer mechanical seal
9	Impeller
10	Diffuser
11	Strainer
12	Oil plug
13	Motor

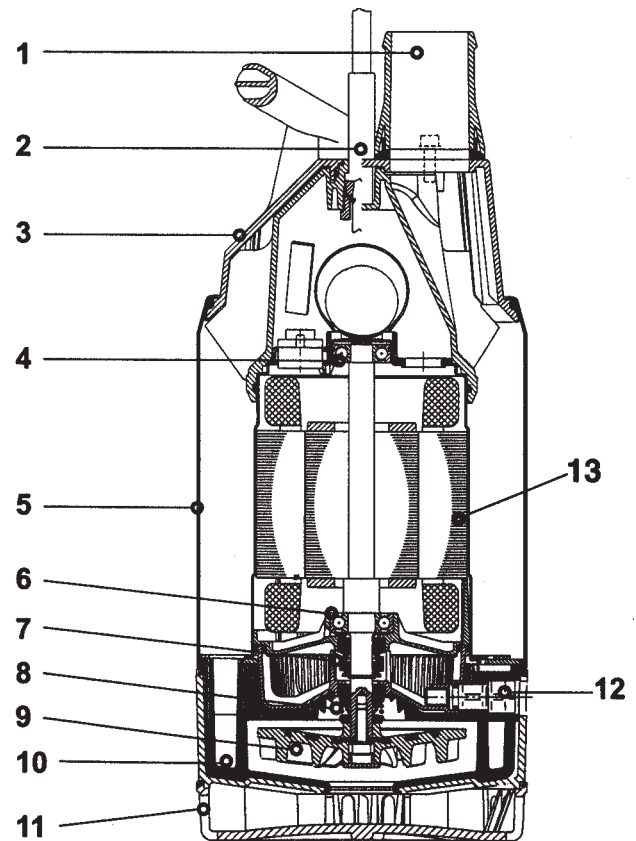

#### RED JACKET WATER PRODUCTS LIMITED WARRANTY

This warranty applies to all water systems pumps manufactured by Red Jacket Water Products.

Any part or parts found to be defective within the warranty period shall be replaced at no charge to the dealer during the warranty period. The warranty period shall exist for a period of twelve (12) months from date of installation or eighteen (18) months from date of manufacture, whichever period is shorter.

Red Jacket Water Products (the manufacturer) warrants to the original end-user Purchaser of each of the Manufacturer's Red Jacket Waterbear, Grizzly and Enduro submersible pumps that any part thereof which proves to be defective in material or workmanship within 36 months from manufacture date will be replaced at no charge with a new or re-manufactured part, F.O.B. factory. In the case of the Big-Flo submersible pump and motor unit and all jet and centrifugal pumps, however, the warranty period shall be the earlier of 24 months from the date of manufacture or 12 months from the date of installation.

A dealer who believes that a warranty claim exists must contact the authorized Red Jacket Water Products distributor from whom the pump was purchased and furnish complete details regarding the claim. The distributor is authorized to adjust any warranty claims utilizing the Red Jacket Water Products Customer Service Department.

**The warranty excludes:**

- (a) Labor, transportation and related costs incurred by the dealer;
- (b) Reinstallation costs of repaired equipment;
- (c) Reinstallation costs of replacement equipment;
- (d) Consequential damages of any kind; and,
- (e) Reimbursement for loss caused by interruption of service.

**For purposes of this warranty, the following terms have these definitions:**

- (1) "Distributor" means any individual, partnership, corporation, association, or other legal relationship that stands between Red Jacket Water Products and the dealer in purchases, consignments or contracts for sale of the subject pumps.
- (2) "Dealer" means any individual, partnership, corporation, association, or other legal relationship which engages in the business of selling or leasing pumps to customers.
- (3) "Customer" means any entity who buys or leases the subject pumps from a dealer. The "customer" may mean an individual, partnership, corporation, limited liability company, association or other legal entity which may engage in any type of business.

**THIS WARRANTY EXTENDS TO THE DEALER ONLY.**

Red Jacket Water Products is a licensed trademark.

Red Jacket Water Products is a brand of ITT Water Technology, Inc. – a subsidiary of ITT Industries, Inc.

Red Jacket Water Products and the ITT Engineered Blocks Symbol are registered trademarks and tradenames of ITT Industries.