



# ITT

Residential Water Systems

## Red Jacket Water Products

**DRJ** 60 Hz Convertible  
Jet Pump



### FEATURES

---

- May be used on shallow or deep well applications using appropriate fittings.
- Back pullout design allows disassembly of pump for service without disturbing piping.
- Two compartment motor for easy access to motor wiring and replaceable components.
- Motor rated for continuous duty.
- Corrosion resistant, engineered plastic tubing and fittings. Premium O-ring design fittings need only be hand tight to seal.
- Impeller is F.D.A. compliant, glass filled Noryl®. Corrosion and abrasion resistant.
- Diffuser (Guidevane) is F.D.A. compliant, injection molded, food grade, glass filled Lexan® for durability and abrasion resistance.
- O-ring casing seal.
- Drain plug for ease of winterizing and maintenance.
- After initial priming the pump has the ability to re-prime itself even when air enters the system.
- Deep well systems require a pressure control valve. See the deep well performance data for suggestions.



Red Jacket Water Products is a brand of ITT Corporation.

[www.redjacketwaterproducts.com](http://www.redjacketwaterproducts.com)

*Engineered for life*



# ITT

## RED JACKET WATER PRODUCTS Residential Water Systems

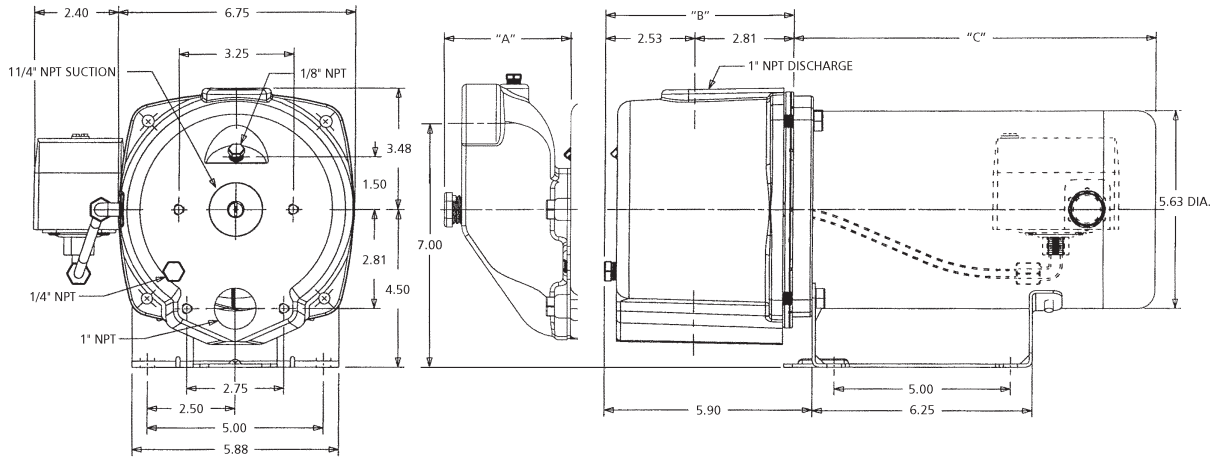

### Dimensions and Weights – Pump, Motor and Shallow Well Adapter

Order No.	HP	(Inches)				Height (Inches)		Wt. (lbs.)
		Opt. SW Adapter "A"	"B"	"C" Max.	Width	Shallow Well	Deep Well	
50DRJ	1/2	3.31	5.34	10.81	9.15	8.41	8.0	37
75DRJ	3/4			11.56				42
100DRJ	1			11.81				47

Do not use for construction purposes.

### Shallow Well Performance Ratings

Approximate Capacity (GPM) at Discharge Pressure											
Model	HP	Depth to Water (feet)	Injector Order No.	20 PSI	30 PSI	40 PSI	50 PSI	60 PSI	Shut-Off PSI	Pressure Switch Setting	Suction and Disch. Size
50DRJ	1/2	5	SW5	12.3	12.0	9.0	4.0	–	63	30 – 50	1 1/4" x 1"
		10		11.0	10.8	7.6	3.0	–	62		
		15		9.2	9.0	6.5	2.5	–	60		
		20		7.6	7.5	5.5	1.5	–	57		
		25		5.7	5.5	4.0	0.6	–	55		
75DRJ	3/4	5	SW7	–	19.0	16.5	10.5	–	69		
		10		–	16.0	14.5	9.0	–	67		
		15		–	13.5	13.0	7.0	–	65		
		20		–	12.0	11.5	5.5	–	63		
		25		–	9.0	8.7	4.0	–	60		
100DRJ	1	5	SW10	–	22.0	21.0	15.0	8.0	72		
		10		–	18.5	18.0	12.5	6.5	70		
		15		–	16.0	15.5	11.0	5.0	68		
		20		–	13.3	13.0	9.0	3.0	65		
		25		–	9.6	9.0	7.0	1.5	63		

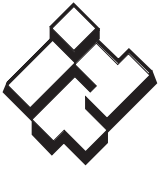

# ITT

## RED JACKET WATER PRODUCTS Residential Water Systems

### 4" Double (Twin) Pipe Performance Ratings in GPM

Depth to Jet Assembly with 5' Minimum Submergence																		
Model	HP	Injector	30'	40'	50'	60'	70'	80'	90'	100'	110'	Pressure Control Valve Setting <sup>①</sup>	Pressure Switch Setting	Suction and Disch. Size				
50DRJ	½	T134DB	11.7	10.7	9.3							30	30 – 50	1¼" x 1"				
		T314DB	10.0	8.0	6.8	6.2	5.0					30						
		T084DB				4.7	4.2	3.3	2.8			30						
75DRJ	¾	T144DB	13.3	13.2	11.3	8.8						30			30 – 50	1¼" x 1"		
		T344DB				8.0	7.0	5.7	4.2			30						
		T184DB							4.5	3.7	3.0	30						
100DRJ	1	T444DB	14.5	14.3	12.3	9.8						31					30 – 50	1¼" x 1"
		T434DB				9.5	8.0	6.3				33						
		T184DB							5.3	5.2	4.7	3.8						

### 2" Single Pipe (Packer) Performance Ratings in GPM

Depth to Jet Assembly with 5' Minimum Submergence																				
Model	HP	Injector	30'	40'	50'	60'	70'	80'	90'	100'	Right Angle Well Adapter	Pressure Control Valve Setting <sup>①</sup>	Pressure Switch Setting	Suction and Disch. Size						
50DRJ	½	P132DB	10.7	9.5	8.3						RAA2	30	30 – 50	1¼" x 1"						
		P312DB	8.5	7.3	6.7	5.8						30								
		P082DB				4.3	3.8	3.2				30								
75DRJ	¾	P402DB	11.8	11.5	9.8	7.7						RAA2			30	30 – 50	1¼" x 1"			
		P472DB				6.7	6.0	4.3	3.7						32					
100DRJ	1	P482DB	14.2	12.5	11.5	9.3									RAA2			35	30 – 50	1¼" x 1"
		P432DB				7.8	7.7	6.3	4.8	3.7								36		

① Deep well jet pumps require a pressure control valve for proper operation. It can be a gas cock, ball valve, or an RJAV22 control valve which includes all needed fittings and longer tubing.

Water Pumps from Red Jacket are the natural choice of well drillers, pump installers and home owners alike. Built on over 120 years of engineering excellence, the name Red Jacket has become synonymous with quality for generations of customers who enjoy well water. The DRJ Convertible jet pump is no exception. This rugged, fast priming, convertible jet pump is designed to provide excellent performance in the most demanding applications. Whether your needs are home or farm, choose a Red Jacket pump generations have come to count on.



**ITT**

**Residential Water Systems**



**RED JACKET®**

**Water Products**

Red Jacket Water Products is a licensed trademark. The ITT Engineered Blocks Symbol are registered trademarks and tradenames of ITT Corporation.

Noryl and Lexan is a registered trademark of GE Plastic.

SPECIFICATIONS ARE SUBJECT TO CHANGE WITHOUT NOTICE.

**BRJDRJ March, 2008**

© 2008 ITT Corporation

*Engineered for life*